

**SIMPLE FABRICATION  
VARIOUS DESIGN OPTIONS**

Corner connection is made with the help of pin-type fastenings or using crimping machine. There are various options of the bottom door rail.

Two options of the threshold: "warm" threshold made of thermo insulated profile and "cold" made of profile without thermal break. It is also possible to install doors into a window frame.



There is no need in complex fabrication of the bottom door rail:

- bottom door rail is cut to size;
- butt-ends are covered with end plugs;
- excellent insulation is provided.



A double door can be made using a double casement profile or without using it.



Plastic adapters are used for threshold installation. There is no need in additional threshold machining.



Symmetrical custom angle connector to make a turn 85° up to 240° is available.

You can see our products at thousands of projects worldwide and at various international exhibitions. ALT architectural systems are tested according to US and European standards.



**ALUMINTECHNO LLC.**  
12 Selitskogo Street, Minsk,  
220075 Republic of Belarus  
phone: +375 (17) 345 81 43, 45  
fax: +375 (17) 345 81 48  
www.alutech-group.com



ALT W62 Window  
and door system  
with thermal break





## ALT W62 WINDOW AND DOOR SYSTEM WITH THERMAL BREAK

The ALT W62 system is a series of thermally insulated profiles designed for the assemblage of windows, doors and entrances with high thermal and soundproof requirements.

### The ALT W62 series of profiles and accessories allows to manufacture:

#### WINDOWS

- fixed
- single sash
- double casement
- double sash with transom
- facade integrated



#### DOORS

- single
- double
- outside/inside opening
- with threshold
- facade integrated



DIFFERENT COMBINATIONS of windows and doors available.

High-quality glass-filled polyamide thermal breaks and variety of new design solutions ensure optimal thermal and static performances of the system and high rigidity of connections.

## ADVANTAGES OF THE SYSTEM

#### FLEXIBILITY

The optimization of stocks is provided due to the use of a number of components (more than 30 items) compatible with other ALT systems - ALT C48, ALT W72, ALT110.

#### MULTIPLE DESIGN OPTIONS

The system's profiles have been designed in a straight functional style. Versatility and attractiveness of the system is attained due to the possibility to select among different variants of assembly solutions. Profiles with narrow visible part allow manufacturing of constructions with maximum glazing area.

#### HIGH WATER AND AIR TIGHTNESS - AW RATINGS ACHIEVED

Double sealing contour between frame and sash provides optimal air infiltration and water penetration resistance parameters. The possibility to install the third sealing contour is provided.

#### COMPATIBLE WITH HARDWARE FROM VARIOUS MANUFACTURERS

There is a "euro groove" in the window series of ALT W62 system that allows utilization of widely popular hardware.

#### HIGH THERMAL INSULATION

Thermal transmittance of a window made of ALT W62 system with a triple IGU is 1,3 W/(m<sup>2</sup>K) in accordance with EN 14351-1:2006+A1:2010.

#### DIFFERENT OPTIONS OF INFILLS

It is possible to install the infill units up to 1 37/64" (40 mm) wide: glass units, sandwich panels etc.

#### WIDE RANGE OF COLORS

The polyamide insert allows painting of internal and external parts of the profiles in different colors that widens possibilities of internal and external decoration of buildings.

## INVENTORY OPTIMIZATION

The same size of the profile chamber in window frame and sash allows to reduce the range of clamping corners.

The use of one type of the transom bar and universal fastening profile for internal and external chambers of the transom bar provides optimal static characteristics of the products and stability of assembly solutions of the system.

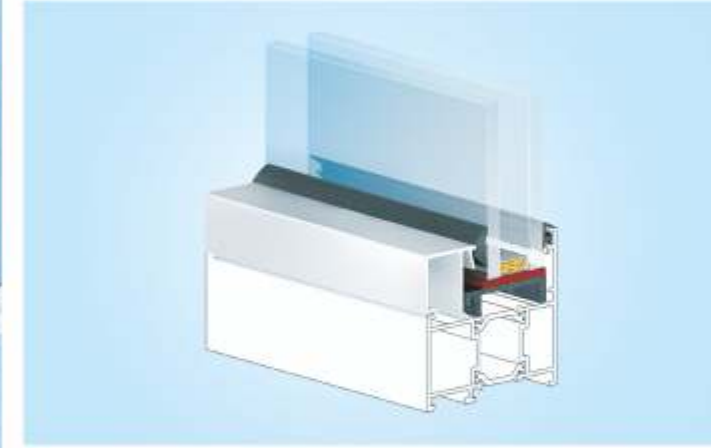
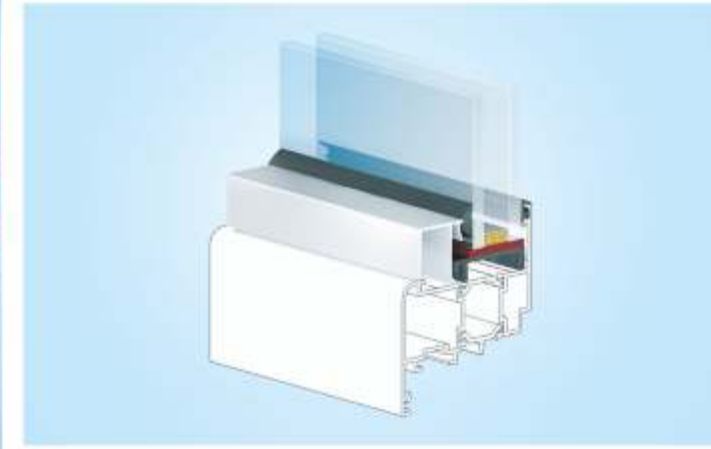
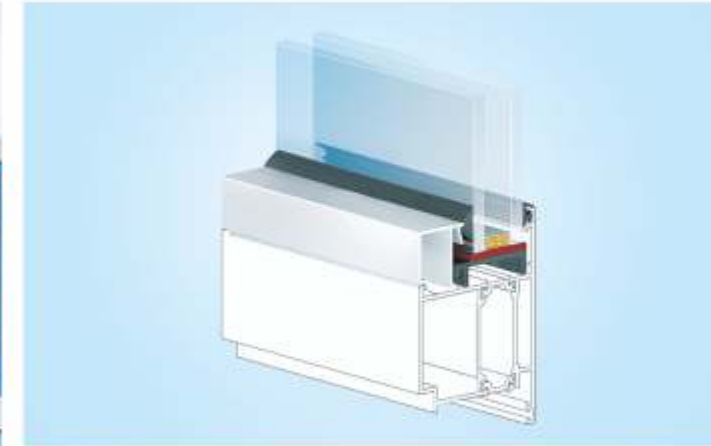

One universal kit including two gaskets, glass bead profile and a bearing plate is used for the installation of same thickness infill unit in doors and windows assemblage.

## TIME-SAVING FABRICATION

Maintainability of the door thresholds is provided by plastic connection elements therefore repair can be carried out without dismantling of the door.

The corner clamping of frames and sashes is carried out without crimping machine readjustment.

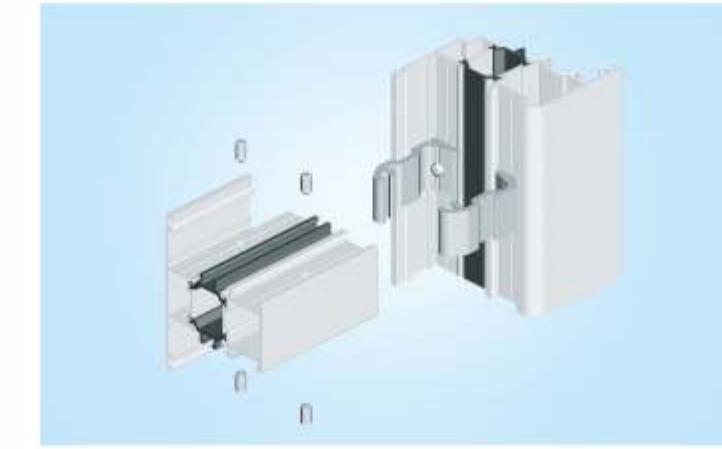

Machining and fixation methods of transom bar profile are the same for all profiles. Simple assemblage of an expansion joint in continuous glazing is possible due to installation of a thermal compensation profile.

